

TIPO IMG12

ASIENTO G06

10 m/s

12 bars

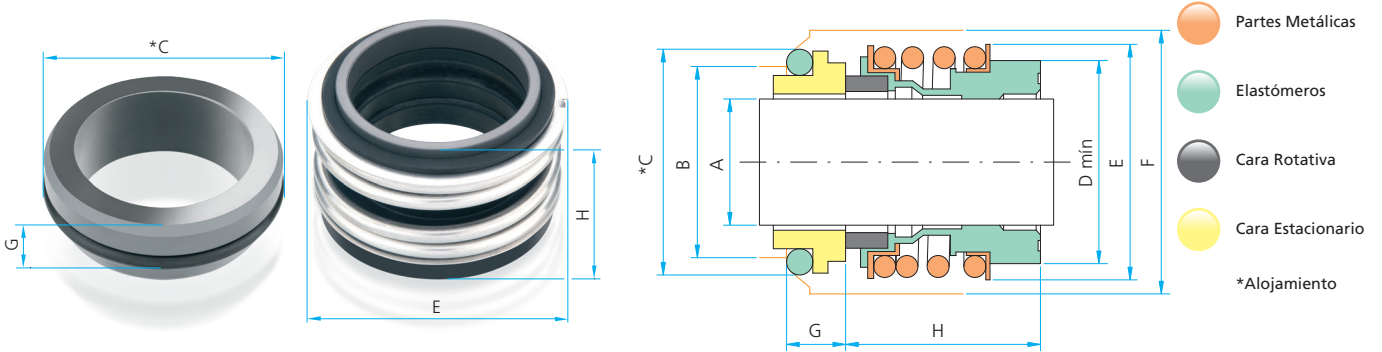

Ítem	CODIFICACIÓN DEL SELLO										Ø A (mm) ± 0,05	Ø B (mm) ± 0,1	Ø C (mm) ± 0,05	Ø D (mm)	Ø E (mm)	Ø F (mm)	G (mm)	H (mm)	
	Tipo & Eje	Conjunto Rotativo	Elementos Empaque			Cara Rotativa	Partes Metálicas		Asiento Estacionario										Conjunto Estacionario
			B Nitrilica	E E.P.D.M.	V Viton®		S Carburo de Silicio	T Carburo de Tungsténio	U Carbón	4 Acero Inoxidable 304									
1	IMG12008	S								G06	-	-	-	-	-	-	-		
2	IMG12010	S								G06	10	17,0	21,0	20,5	22,5	24,0	6,6	25,9	
3	IMG12012	S								G06	12	19,0	23,0	22,5	25,0	26,0	6,6	25,9	
4	IMG12014	S								G06	14	21,0	25,0	26,5	28,5	30,0	6,6	28,4	
5	IMG12015	S								G06	-	-	-	-	-	-	-	-	
6	IMG12016	S								G06	16	23,0	27,0	26,5	28,5	30,0	6,6	28,4	
7	IMG12018	S								G06	18	27,0	33,0	29,0	32,0	33,0	7,5	30,0	
8	IMG12019	S								G06	-	-	-	-	-	-	-	-	
9	IMG12020	S								G06	20	29,0	35,0	33,0	37,0	38,0	7,5	30,0	
10	IMG12022	S								G06	22	31,0	37,0	33,0	37,0	38,0	7,5	30,0	
11	IMG12024	S								G06	24	33,0	39,0	38,0	42,5	44,0	7,5	32,5	
12	IMG12025	S								G06	25	34,0	40,0	38,0	42,5	44,0	7,5	32,5	
13	IMG12028	S								G06	28	37,0	43,0	44,0	49,0	50,0	7,5	35,0	
14	IMG12030	S								G06	30	39,0	45,0	44,0	49,0	50,0	7,5	35,0	
15	IMG12032	S								G06	32	42,0	48,0	46,0	53,5	55,0	7,5	35,0	
16	IMG12033	S								G06	-	-	-	-	-	-	-	-	
17	IMG12035	S								G06	35	44,0	50,0	50,0	57,0	59,0	7,5	35,0	
18	IMG12038	S								G06	38	49,0	56,0	53,0	59,0	61,0	9,0	36,0	
19	IMG12040	S								G06	40	51,0	58,0	55,0	62,0	64,0	9,0	36,0	
20	IMG12042	S								G06	-	-	-	-	-	-	-	-	

## TIPO IMG12

## ASIENTO G06

Ítem	CODIFICACIÓN DEL SELLO							Ø A (mm) ± 0,05	Ø B (mm) ± 0,1	Ø C (mm) ± 0,05	Ø D (mm)	Ø E (mm)	Ø F (mm)	G (mm)	H (mm)		
	Tipo & Eje	Conjunto Rotativo	Elementos Empaque			Cara Rotativa	Partes Metálicas									Asiento Estacionario	Conjunto Estacionario
			B Nitrilica	E E.P.D.M.	V Viton®												
21	IMG12043	S						G06	43	54,0	61,0	58,0	65,5	67,0	9,0	36,0	
22	IMG12045	S						G06	45	56,0	63,0	60,0	68,0	70,0	9,0	36,0	
23	IMG12048	S						G06	48	59,0	66,0	63,0	70,5	74,0	9,0	36,0	
24	IMG12050	S						G06	50	62,0	70,0	65,0	74,0	77,0	9,5	38,0	
25	IMG12053	S						G06	53	65,0	73,0	70,0	78,5	81,0	11,0	36,5	
26	IMG12055	S						G06	55	67,0	75,0	72,0	81,0	83,0	11,0	36,5	
27	IMG12058	S						G06	58	70,0	78,0	75,0	85,5	88,0	11,0	41,5	
28	IMG12060	S						G06	60	72,0	80,0	79,0	88,5	91,0	11,0	41,5	
29	IMG12065	S						G06	65	77,0	85,0	84,0	93,5	96,0	11,0	41,5	
30	IMG12068	S						G06	68	81,0	90,0	88,0	96,5	100,0	11,3	41,2	
31	IMG12070	S						G06	70	83,0	92,0	90,0	99,5	103,0	11,3	48,7	
32	IMG12075	S						G06	75	88,0	97,0	95,0	107,0	110,0	11,3	48,7	
33	IMG12080	S						G06	80	95,0	105,0	100,0	112,0	116,0	12,0	48,0	
34	IMG12085	S						G06	85	100,0	110,0	107,0	120,0	124,0	14,0	46,0	
35	IMG12090	S						G06	90	105,0	115,0	114,0	127,0	131,0	14,0	51,0	
36	IMG12095	S						G06	95	110,0	120,0	119,0	132,0	136,0	14,0	51,0	
37	IMG12100	S						G06	100	115,0	125,0	124,0	137,0	140,0	14,0	51,0	