

TIPO IMG13

ASIENTO G13

10 m/s

12 bars

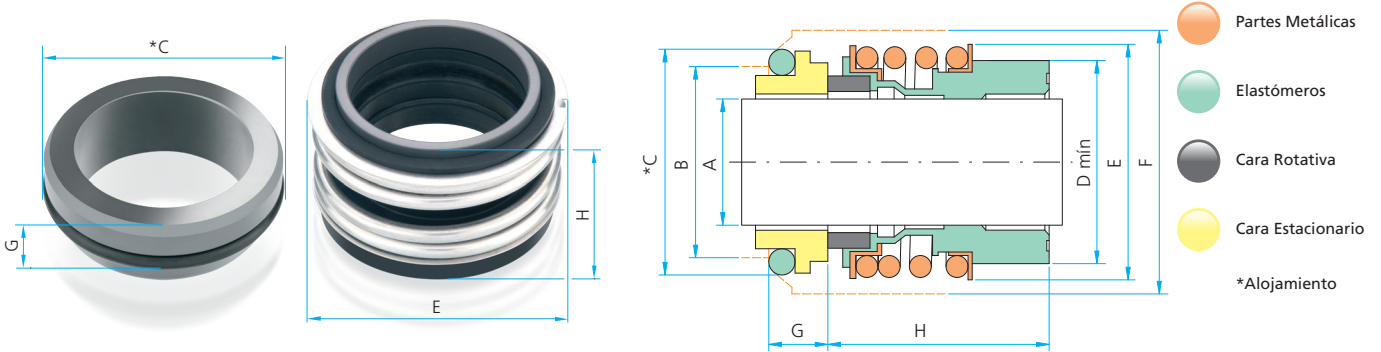

Ítem	CODIFICACIÓN DEL SELLO										Ø A (mm) ± 0,05	Ø B (mm) ± 0,1	Ø C (mm) ± 0,05	Ø D (mm)	Ø E (mm)	Ø F (mm)	G (mm)	H (mm)	
	Tipo & Eje	Conjunto Rotativo	Elementos Empaque			Cara Rotativa	Partes Metálicas		Asiento Estacionario										Conjunto Estacionario
			B Nitrílica	E E.P.D.M.	V Viton®		S Carburo de Silicio	T Carburo de Tungsténio	U Carbón	4 Acero Inoxidable 304									
1	IMG13008	S								G13	-	-	-	-	-	-	-		
2	IMG13010	S								G13	10	15,5	19,2	20,5	22,5	24,0	7,1	33,4	
3	IMG13012	S								G13	12	17,5	21,6	22,5	25,0	26,0	7,6	33,4	
4	IMG13014	S								G13	14	20,5	24,6	26,5	28,5	30,0	7,6	33,4	
5	IMG13015	S								G13	15	20,5	24,6	26,5	28,5	30,0	8,6	33,4	
6	IMG13016	S								G13	16	22,0	28,0	26,5	28,5	30,0	9,0	33,4	
7	IMG13018	S								G13	18	24,0	30,0	29,0	32,0	33,0	10,0	37,5	
8	IMG13019	S								G13	-	-	-	-	-	-	-	-	
9	IMG13020	S								G13	20	29,5	35,0	33,0	37,0	38,0	9,5	37,5	
10	IMG13022	S								G13	22	29,5	35,0	33,0	37,0	38,0	9,5	37,5	
11	IMG13024	S								G13	24	32,0	38,0	38,0	42,5	44,0	9,5	42,5	
12	IMG13025	S								G13	25	32,0	38,0	38,0	42,5	44,0	9,5	42,5	
13	IMG13028	S								G13	28	36,0	42,0	44,0	49,0	50,0	11,0	42,5	
14	IMG13030	S								G13	30	39,2	45,0	44,0	49,0	50,0	11,0	42,5	
15	IMG13032	S								G13	32	42,2	48,0	46,0	53,5	55,0	11,0	47,5	
16	IMG13033	S								G13	33	44,2	50,0	46,0	53,5	55,0	11,5	47,5	
17	IMG13035	S								G13	35	46,2	52,0	50,0	57,0	59,0	11,5	47,5	
18	IMG13038	S								G13	38	49,2	55,0	53,0	59,0	61,0	11,5	46,0	
19	IMG13040	S								G13	40	52,2	58,0	55,0	62,0	64,0	11,5	46,0	
20	IMG13042	S								G13	-	-	-	-	-	-	-	-	

TIPO IMG13

ASIENTO G13

Ítem	CODIFICACIÓN DEL SELLO										Ø A (mm) ± 0,05	Ø B (mm) ± 0,1	Ø C (mm) ± 0,05	Ø D (mm)	Ø E (mm)	Ø F (mm)	G (mm)	H (mm)		
	Tipo & Eje	Conjunto Rotativo	Elementos Empaque			Cara Rotativa		Partes Metálicas		Asiento Estacionario									Conjunto Estacionario	
			B Nitrílica	E E.P.D.M.	V Viton®	S Carburo de Silicio	T Carburo de Tungsténio	U Carbón	4 Acero Inoxidable 304	6 Acero Inoxidable 316										R Cerámica (Al ₂ O ₃)
21	IMG13043	S									G13	43	53,3	62,0	58,0	65,5	67,0	14,3	51,0	
22	IMG13045	S									G13	45	55,3	64,0	60,0	68,0	70,0	14,3	51,0	
23	IMG13048	S									G13	48	59,7	68,4	63,0	70,5	74,0	14,3	51,0	
24	IMG13050	S									G13	50	60,8	69,3	65,0	74,0	77,0	14,3	50,5	
25	IMG13053	S									G13	53	63,8	72,3	70,0	78,5	81,0	14,3	59,0	
26	IMG13055	S									G13	55	66,5	75,4	72,0	81,0	83,0	15,3	59,0	
27	IMG13058	S									G13	58	69,5	78,4	75,0	85,5	88,0	15,3	59,0	
28	IMG13060	S									G13	60	71,5	80,4	79,0	88,5	91,0	15,3	59,0	
29	IMG13065	S									G13	65	76,5	85,4	84,0	93,5	96,0	15,3	69,0	
30	IMG13068	S									G13	68	82,7	91,5	88,0	96,5	100,0	16,0	68,7	
31	IMG13070	S									G13	70	83,0	92,0	90,0	99,5	103,0	15,3	68,7	
32	IMG13075	S									G13	75	90,2	99,0	95,0	107,0	110,0	15,3	68,7	
33	IMG13080	S									G13	80	95,2	104,0	100,0	112,0	116,0	16,3	78,0	
34	IMG13085	S									G13	85	100,2	109,0	107,0	120,0	124,0	16,3	76,0	
35	IMG13090	S									G13	90	105,2	114,0	114,0	127,0	131,0	16,3	76,0	
36	IMG13095	S									G13	95	111,6	120,3	119,0	132,0	136,0	17,3	76,0	
37	IMG13100	S									G13	100	114,5	123,3	124,0	137,0	140,0	17,3	76,0	